

Item # _____

Project: _____

Qty: _____

*AutoCad available on KCL

KM-1900S_H

STACKABLE ICE CUBER

KM-1900S_H

32 4

CUBER DIMENSIONS



W x D x H

KM-1900S_H
48 x 27^{3/8} x 36^{7/16}

KM-1900SAH

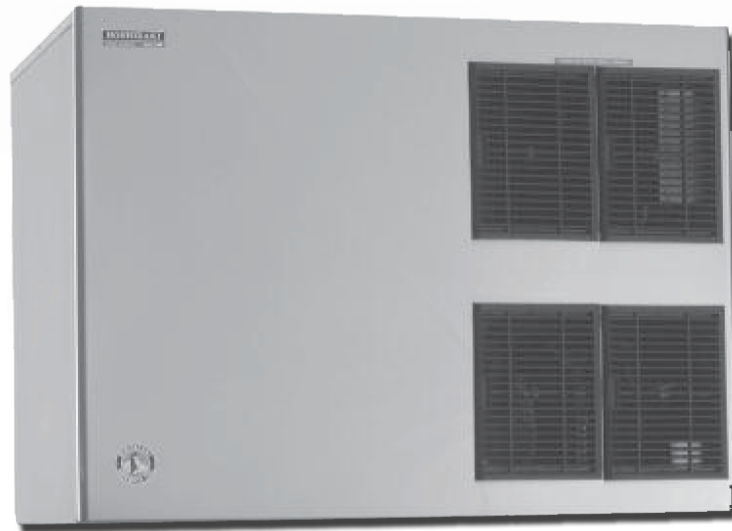
Air-Cooled I Phase



- Up to 1965 lbs. of ice production per 24 hours
- Durable stainless steel exterior
- Protected by *HoshiGuard* Antimicrobial Agent 
- CycleSaver® design 
- EverCheck® alert system 
- Individual crescent cube
- Stainless steel evaporator
- Stackable for 3930 lbs. per 24 hour ice production in the same floor space
- Removable air filters (Air-cooled model only)
- R-404A Refrigerant
- Complies with California Energy Commission guidelines (CEC)

* The KM-1900SAH, KM-1900SAH3, KM-1900SRH and KM-1900SRH3 are ENERGY STAR certified.



Warranty

Valid in United States, Canada, Puerto Rico, & U.S. Territories. Contact factory for warranty in other countries.

Three Year - Parts & Labor on entire machine.

Five Year - Parts & Labor on: Evaporator.

Five Year - Parts on: Compressor, air-cooled condenser coil.



© HOSHIZAKI AMERICA, INC.

618 Hwy. 74 S., Peachtree City, GA 30269

TEL 1-800-438-6087

FAX 1-800-345-1325

www.hoshizaki.com

Hoshizaki

KM-1900S_H STACKABLE ICE CUBER

DIMENSIONS
W x D x H
KM-1900S_H(3)
48 x 27^{3/8} x 36^{7/16}

STACKABLE ICE CUBER

- Air-cooled 1 phase

AIR - COOLED 1 PHASE /

| Water Temp° F. | 50° | 70° | 90° |
|------------------|-------------|--------------------|-------------|
| Air Temp° F. 70° | 1867 / 1859 | 1777 / 1763 | 1638 / 1633 |
| 80° | 1798 / 1786 | 1659 / 1636 | 1511 / 1507 |
| 90° | 1777 / 1763 | 1560 / 1530 | 1413 / 1398 |

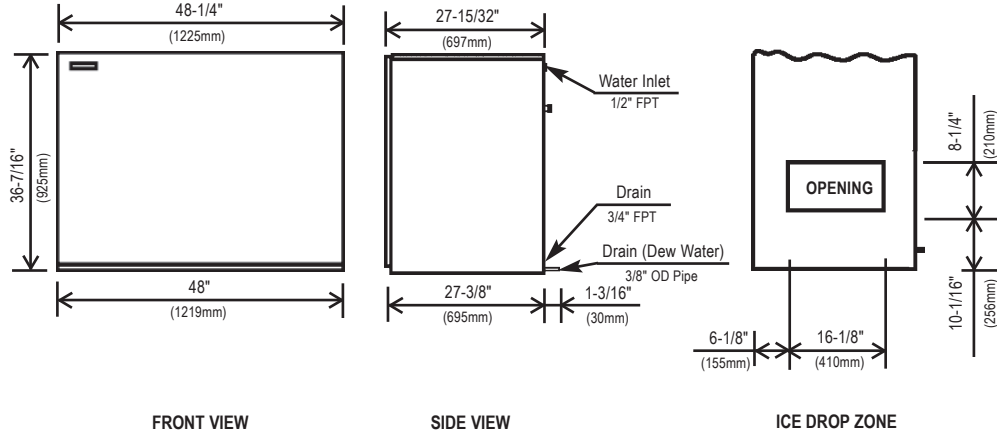

UTILITY CONSUMPTION

| Model Number | Ice Production Per Cycle | | KWH per 100 LBS. | Potable Water Gal. per 100 lbs. | Condenser Water Gal. per 100 lbs. |
|--------------|--------------------------|-------|------------------|---------------------------------|-----------------------------------|
| | Lbs. | Cubes | | | |
| KM-1900SAH | 45.3 | 2160 | 4.1 | 18.8 | N/A |

SPECIFICATIONS

| Model Number | Condenser | Amperage | Min. Circuit Ampacity | Shipping Weight |
|--------------|------------|----------|-----------------------|-----------------|
| KM-1900SAH | Air-Cooled | 14.4 | 30 | 415 lbs. |

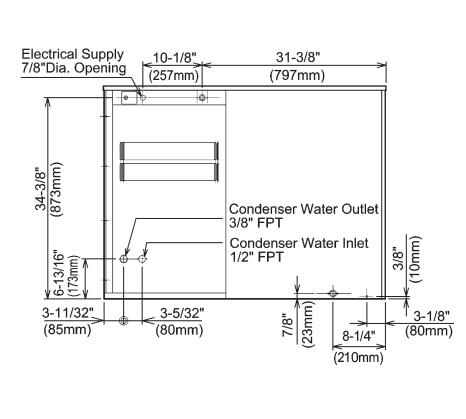
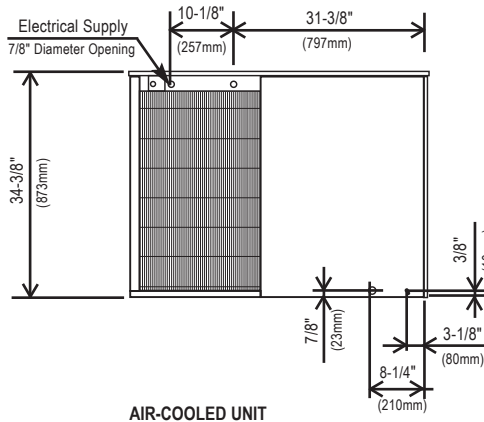

B-1650 1605 lbs. N/A

ELECTRICAL & PLUMBING / KM-1900S_H(3)

- KM-1900SAH
- 208 - 230V/60/1ø (3 wire with neutral for 115V)
 - 30 amp Max Fuse/HACR Breaker Size

OPERATING LIMITS

- Ambient Temp Range 45 - 100°F
- Water Temp Range 45 - 90°F
- Water Pressure 10 - 113psig
- Voltage Range 187 - 253V

SERVICE

- Panels easily removed and all components accessible for service.
- Removable/cleanable air filters (Air-cooled model only)

CONDENSING UNIT

- Voltage Range 104 - 127V
- Ambient Temp Range -20 - 122°F



© HOSHIZAKI AMERICA, INC.

618 Hwy. 74 S., Peachtree City, GA 30269

TEL 1-800-438-6087

FAX 1-800-345-1325

www.hoshizaki.com

Printed in U.S.A.

