



MODELS **400AR**
400SM

2,000 lbs.

**of hard
cracked ice
in 24 hrs.
(907 Kg.)**

Arctic-Temp is the developer and leading producer of VERTICAL TUBE INDUSTRIAL ICE MACHINES. We provide a straight-forward, uncomplicated design that provides maximum ice production while using less electricity than other ice machines in this capacity range.

- » **Highly efficient Copeland Compressor.**
- » **Double Walled Vertical Tube Evaporators For Maximum Production.**
- » **Hot Gas Defrost for rapid harvest and quick recovery.**
- » **All Stainless Steel Welded Construction.**
- » **No moving parts in the freezing zone.**
- » **Harvest Hold (PHC) for definite defrost in varying temperature.**
- » **R-404A Refrigerant.**
- » **Factory Assembled, Fully Charged & Tested.**
- » **USDA Approved.**



Condensing unit shown with protective cover

» **PLEASE REFER TO OUR GENERAL CATALOG FOR ADDITIONAL INFORMATION AND SPECIFICATIONS ON ARCTIC-TEMP ICE MAKERS.**



QUALITY INDUSTRIAL ICE MACHINES SINCE 1959

Manufactured by HOLIDAY ICE, Inc. • 204 Short Avenue • Longwood, FL 32750-5130
Phone (407) 831-2077 • FAX (407) 834-3359 • www.arctic-temp.com
Arctic-Temp is a Registered Trademark of Holiday Ice, Inc. © Copyright 2010 by Holiday Ice, Inc. All Rights Reserved.

DIMENSIONAL DATA
TOP VIEW

ICE MACHINE
400SM SKID MOUNT

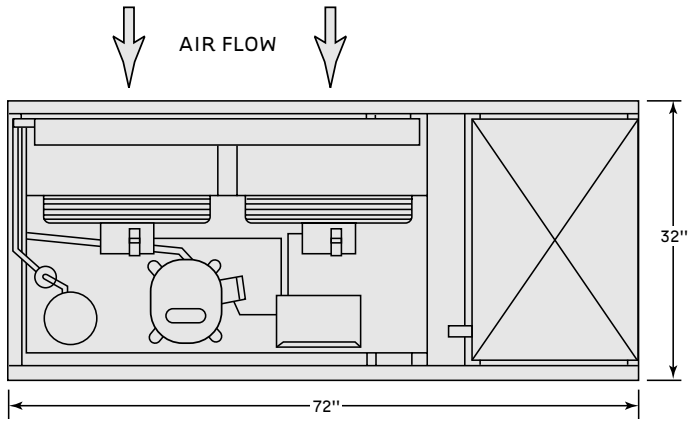

SPECIFICATIONS
ARCTIC-TEMP® MODEL 400AR

ICE PRODUCTION (LBS.) in 24 Hours	2,000		
COMPRESSOR HORSEPOWER	4		
ELECTRICAL V/HZ/PH	208/230-1-60 208/230-3-60 200-1-50		
METHOD OF CONDENSING	AIR REMOTE		
DIMENSIONS JACKETED	HEIGHT	57"	
	WIDTH	28"	
	DEPTH	19"	
CONDENSING UNIT DIMENSIONS	LENGTH	46"	
	WIDTH	34"	
	HEIGHT	35"	
REFRIGERANT CHARGE	15 LBS.		
APPROX.. MACHINE WEIGHT (LBS.)	UNCRATED	EVAP	215 LBS.
		COND	300 LBS.
	CRATED	EVAP	293 LBS.
		COND	385 LBS.
WATER CONSUMPTION (GAL./24 HRS.)	240		

ARCTIC-TEMP MODEL 400SM

In certain applications where roof mounting or custom bunker mounting is desired, it may be economical to Skid Mount the highside and lowside components on a common base in order to obtain a PACKAGED ICE MACHINE.

ALL PACKAGED ICE MACHINES are fully assembled and thoroughly tested prior to shipping.

Holiday Ice can perform your custom work to make the installation easier, future service more convenient, and reduce the installation costs.

ADDITIONAL SPECIFICATIONS
FOR SKID MOUNTING:

BASE	LENGTH	72"
DIMENSIONS	WIDTH	32"
	HEIGHT	60"
APPROX.. WEIGHT (LBS.)	650	

